



ARCOSA

SHORING PRODUCTS

Slide Rail Shoring System Tabulated Data

*Copyright, U.S.A., Pro-Tec Equipment,
4837 West Grand River Ave, Lansing, MI 48906
(800) 292-1225*



CAUTION

EXCAVATION PROCEDURES MAY CAUSE INJURY OR DEATH!

A COMPETENT PERSON WHO SATISFIES THE DEFINITION AND INTENT OF THE 1926 CONSTRUCTION STANDARD SUBPART P EXCAVATIONS SHALL: ENSURE THAT ALL EMPLOYEES ARE WORKING IN SAFE CONDITIONS AND THAT ALL EMPLOYEES HAVE BEEN TRAINED IN CORRECT EXCAVATION PROCEDURES AND THE PROPER USE OF THE PROTECTIVE EQUIPMENT CHOSEN.

EXCAVATIONS AND PROTECTIVE EQUIPMENT SHALL BE INSPECTED A MINIMUM OF ONCE EACH WORKING DAY AND WHENEVER THERE IS A CHANGE IN THE SOIL CONDITIONS AND/OR OTHER CHANGES SUCH AS AN INCREASE OR DECREASE IN WATER OR VIBRATIONS.

EMPLOYEES SHALL NOT BE ALLOWED TO ENTER AN EXCAVATION THAT IS NOT PROPERLY SHORED, SHIELDED, OR SLOPED.

EMPLOYEES SHALL ONLY ENTER, WORK, AND EXIT WITHIN THE SHORED, SHIELDED, OR SLOPED AREAS OF THE EXCAVATION AND/OR TRENCH.

ALL LIFTING AND PULLING EQUIPMENT, INCLUDING CABLES, SLINGS, CHAINS, SHACKLES AND SAFETY HOOKS SHALL BE INSPECTED FOR DAMAGE OR DEFECTS PRIOR TO USE AND SHALL BE EVALUATED FOR SUITABILITY AND CAPACITY.

THIS PRO-TEC TABULATED DATA PROVIDES A GENERAL SET OF GUIDELINES TO ASSIST THE COMPETENT PERSON IN THE SELECTION OF A PROTECTIVE SYSTEM FOR EMPLOYEE SAFETY. THE RESPONSIBILITY FOR JOB SITE SAFETY AND THE PROPER SELECTION, INSTALLATION AND REMOVAL OF THE SHORING EQUIPMENT BELONGS TO THE COMPETENT PERSON DESIGNATED FOR THAT JOBSITE. THIS TABULATED DATA IS NOT INTENDED TO BE USED AS A JOB SPECIFIC EXCAVATION/TRENCHING SAFETY PLAN, BUT SHALL BE USED BY THE COMPETENT PERSON. TABULATED DATA IS INTENDED AS A SUPPLEMENT TO HIS/HER TRAINING, EXPERIENCE AND KNOWLEDGE OF SAFE PROCEDURES, JOB SITE CONDITIONS AND SOIL TYPES. TABULATED DATA IS INTENDED TO ASSIST HIM/HER IN THE SELECTION OF AN APPROPRIATE PROTECTIVE SYSTEM FOR EMPLOYEE SAFETY.



SLIDE RAIL SHORING SYSTEM TABULATED DATA

GENERAL:

1. This data has been prepared by a Registered Professional Engineer as required by the OSHA standard 29 CFR, Part 1926, Subpart P, Excavations.
 2. This data is to be used by the "competent person" to ensure the proper use and **placement** of the Pro-Tec Slide Rail System.
 3. "Competent person" is one who is capable of identifying existing and predictable hazards in the surroundings or working conditions which are unsanitary, hazardous, or dangerous to employees, and who has authorization to take prompt corrective measures to eliminate them.
 4. When there is a discrepancy concerning the use of protective systems between this tabulated data and the OSHA standard, this data shall take precedence. Any topic not covered by this data shall be governed by the OSHA standard.
 5. Pro-Tec & DHC shall not be liable for damage or injury resulting from improper use of the Pro-Tec Slide Rail Shoring System. Improper use of or modifications to the structural components without the written consent of Pro-Tec shall void this data and all manufacturer's warranty.
-

Soil Classification

1. See the OSHA regulations for definitions of Type A, B, and C soils.
 2. Type **C-60** soil is a cohesive soil with an unconfined compressive strength of 0.5 tsf or less and granular soils including gravel, sand, and loamy sand which is NOT flowing and is NOT submerged. Equivalent Fluid Pressure (EFP) of 60 psf per foot of depth
-

System Specifications:

1. All personnel involved with the use of Pro-Tec Slide Rail Shoring Systems shall be trained in the proper use and installation procedures and other applicable safety requirements.
2. Depth ratings for slide rail components are based on examples of homogeneous soil conditions. Actual soil pressures should be verified to be sure that the systems structural capacity is not exceeded.



3. Surcharge loads are not included in the depth ratings of the slide rail components. Surcharge loads are possible due to heavy equipment, vibrations, or soil piles adjacent to the excavation. (Adjacent is defined as within a distance equal to the depth of the excavation.) Surcharge loads may cause damage and permanent deformation to slide rail components or adjacent structures/utilities.
4. Refer to post depth rating graphs in order to determine the allowable depth rating, clearance and strut length for the applicable strut, post and post tributary width.
5. Slide rail panels may extend a maximum of 2 ft. beyond the bottom posts.
6. Slide rail panels may be held a maximum of 2 ft. above the bottom of the excavation in stable materials.
7. Allowable strut clearance shall be maintained above and below roller beam.
8. No steel plates, sheet piles, or sheathing of any kind may be leaned against, or otherwise supported by struts at any time. Do not suspend load from struts.



PRO-TEC 8'-TALL PANEL DEPTH RATINGS

MODEL	H X L (FT)	THICKNESS	MOMENT OF INERTIA (in ⁴)	PRESSURE CAPACITY (PSF)	DEPTH RATING (FT)			
					A SOILS	B SOILS	C-60 SOILS	C-80 SOILS
PS-P-86-KE	8' X 6'	4"	203	2400	40'	35'	30'	20'
PS-P-88-KE	8' X 8'	4"	203	2400	40'	35'	30'	20'
PS-P-810-KE	8' X 10'	4"	203	2400	40'	35'	30'	20'
PS-P-812-KE	8' X 12'	4"	201	2400	40'	35'	30'	20'
PS-P-814-KE	8' X 14'	4"	217	2250	40'	35'	30'	20'
PS-P-816-KE-XH	8' X 16'	4"	227	1802	40'	35'	30'	20'
PS-P-816-KE-XXH	8' X 16'	6"	441	2220	40'	35'	30'	20'
PS-P-818-KE-XH	8' X 18'	4"	283	1731	40'	35'	29'	20'
PS-P-818-KE-XXH	8' X 18'	6"	716	2220	40'	35'	30'	20'
PS-P-820-KE-XH	8' X 20'	4"	283	1438	40'	33'	25'	19'
PS-P-820-KE-XXH	8' X 20'	6"	716	1900	40'	35'	30'	20'
PS-P-822-KE-XH	8' X 22'	6"	496	1378	40'	31'	24'	17'
PS-P-822-KE-XXH	8' X 22'	6"	716	1649	40'	35'	27'	20'
PS-P-824-KE-XH	8' X 24'	6"	496	1162	40'	25'	19'	14'
PS-P-824-KE-XXH	8' X 24'	6"	716	1388	40'	31'	24'	17'
PS-P-826-KE-XXH	8' X 26'	6"	790	1380	40'	31'	24'	17'
PS-P-828-KE-XH-I	8' X 28'	8"	820	900	40'	24'	19'	15'
PS-P-828-KE-XH-U	8' X 28'	8"	820	900	40'	24'	19'	15'
PS-P-830-KE-XH-I	8' X 30'	8"	933	800	36'	21'	17'	14'
PS-P-830-KE-XH-U	8' X 30'	8"	933	800	36'	21'	17'	14'

R2



ARCOSA
SHORING PRODUCTS

Notes:

- 1) Pressure and depth ratings include 33% overstress for temporary loading conditions
- 2) Refer to PS-TD-15-0 "Slide Rail Shoring Linear Tabulated Data" for all general safety notes and limitations.

CERTIFIED BY:
MUST BE SIGNED
& DATED

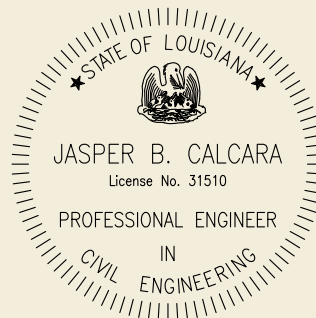

PRO-TEC 4'-TALL PANEL DEPTH RATINGS

MODEL	H X L (FT)	THICKNESS	MOMENT OF INERTIA (in ⁴)	PRESSURE CAPACITY (PSF)	DEPTH RATING (FT)			
					A SOILS	B SOILS	C-60 SOILS	C-80 SOILS

PS-P-46-NK	4' X 6'	4"	115	2400	40'	35'	30'	20'
PS-P-48-NK	4' X 8'	4"	115	2400	40'	35'	30'	20'
PS-P-410-NK	4' X 10'	4"	115	2400	40'	35'	30'	20'
PS-P-412-NK	4' X 12'	4"	115	2300	40'	35'	30'	20'
PS-P-414-NK	4' X 14'	4"	115	1900	40'	35'	30'	20'
PS-P-416-NK	4' X 16'	4"	117	1600	40'	35'	29'	20'
PS-P-418-NK	4' X 18'	4"	115	1243	40'	31'	23'	20'
PS-P-420-NK	4' X 20'	4"	123	1068	40'	27'	20'	15'
PS-P-422-NK-XH	4' X 22'	6"	415	1583	40'	35'	26'	20'
PS-P-424-NK-XH	4' X 24'	6"	294	1290	40'	29'	22'	17'
PS-P-426-NK-XXH	4' X 26'	6"	415	1300	40'	32'	24'	18'
PS-P-428-NK-XH	4' X 28'	8"	473	950	40'	23'	18'	13'
PS-P-430-NK-XH	4' X 30'	8"	473	850	36'	20'	16'	12'

R2



ARCOSA
SHORING PRODUCTS

Notes:

- 1) Pressure and depth ratings include 33% overstress for temporary loading conditions
- 2) Refer to PS-TD-15-0 "Slide Rail Shoring Linear Tabulated Data" for all general safety notes and limitations.

CERTIFIED BY:
MUST BE SIGNED
& DATED

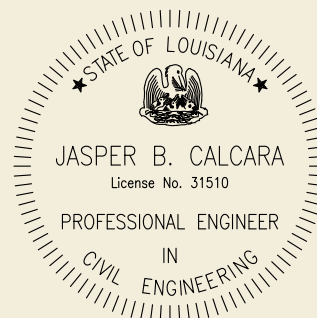



**PRO-TEC
EQUIPMENT**
4837 West Grand River Ave
Lansing, MI 48906
(800) 292-1225

ARCOSA
SHORING PRODUCTS

MANUFACTURER'S TABULATED DATA PS-DSP-236/240

R0

SPECIFICATIONS FOR USE

- 1) THIS TABULATED DATA SHEET IS ONLY TO BE USED TO SUPPLEMENT A SITE SPECIFIC SHORING PLAN WHEN RAILS ARE LOADED IN BENDING AND SHEAR.
- 2) PROFESSIONAL ENGINEER PREPARING SITE SPECIFIC PLAN IS RESPONSIBLE FOR CHECKING ALL COMPONENTS OF SLIDE RAIL SYSTEM AND MIDDLE RAIL ASSEMBLY FOR SOIL AND SURCHARGE LOADING ASSOCIATED WITH SITE SPECIFIC CONDITIONS.
- 3) ALL EXCAVATIONS SHALL BE IN ACCORDANCE WITH OSHA CFR 29, PART 1926, SUBPART P.
- 4) ALL EQUIPMENT COVERED UNDER THIS TABULATED DATA SHALL BE CERTIFIED PRO-TEC EQUIPMENT.
- 5) SLIDE RAIL SHORING SYSTEM SHALL BE USED IN STRICT ACCORDANCE WITH THE REQUIREMENTS OF THE MANUFACTURER.
- 6) EQUIPMENT IS NOT CERTIFIED FOR USE IF ASSEMBLIES ARE MODIFIED IN ANY WAY, UNLESS APPROVED IN WRITING BY A LICENSED ENGINEER.
- 7) CERTIFICATION IS NOT VALID IF THE SHORING SYSTEM SHOWS EXCESSIVE WEAR, IS PERMANENTLY DAMAGED, IS NOT MAINTAINED OR REPAIRED PROPERLY.

MODEL NO:
PS-DSP-236/240

LENGTH:
19.7'/20'



ALLOWABLE MOMENT
M = 564 K-FT

ALLOWABLE SHEAR
V = 465 KIPS

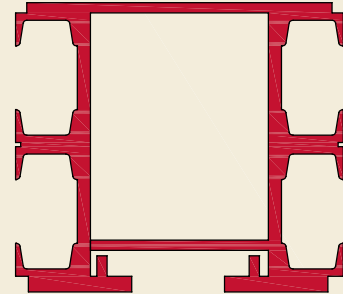

CAPACITY AND DEPTH RATINGS ACCOUNT FOR 33% OVERSTRESS FOR SHORT-TERM LOADING CONDITION.

CERTIFIED BY:
MUST BE SIGNED
& DATED

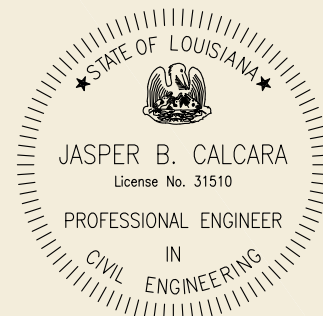



**PRO-TEC
EQUIPMENT**
4837 West Grand River Ave
Lansing, MI 48906
(800) 292-1225

ARCOSA
SHORING PRODUCTS

MANUFACTURER'S TABULATED DATA PS-DCP-216/240

R0

SPECIFICATIONS FOR USE

- 1) THIS TABULATED DATA SHEET IS ONLY TO BE USED TO SUPPLEMENT A SITE SPECIFIC SHORING PLAN WHEN RAILS ARE LOADED IN BENDING AND SHEAR.
- 2) PROFESSIONAL ENGINEER PREPARING SITE SPECIFIC PLAN IS RESPONSIBLE FOR CHECKING ALL COMPONENTS OF SLIDE RAIL SYSTEM AND CORNER RAIL ASSEMBLY FOR SOIL AND SURCHARGE LOADING ASSOCIATED WITH SITE SPECIFIC CONDITIONS.
- 3) ALL EXCAVATIONS SHALL BE IN ACCORDANCE WITH OSHA CFR 29, PART 1926, SUBPART P.
- 4) ALL EQUIPMENT COVERED UNDER THIS TABULATED DATA SHALL BE CERTIFIED PRO-TEC EQUIPMENT.
- 5) SLIDE RAIL SHORING SYSTEM SHALL BE USED IN STRICT ACCORDANCE WITH THE REQUIREMENTS OF THE MANUFACTURER.
- 6) EQUIPMENT IS NOT CERTIFIED FOR USE IF ASSEMBLIES ARE MODIFIED IN ANY WAY, UNLESS APPROVED IN WRITING BY A LICENSED ENGINEER.
- 7) CERTIFICATION IS NOT VALID IF THE SHORING SYSTEM SHOWS EXCESSIVE WEAR, IS PERMANENTLY DAMAGED, IS NOT MAINTAINED OR REPAIRED PROPERLY.

MODEL NO:
PS-DCP-216/240

LENGTH:
18'/20'



ALLOWABLE MOMENT
M = 392 K-FT

ALLOWABLE SHEAR
V = 190 KIPS

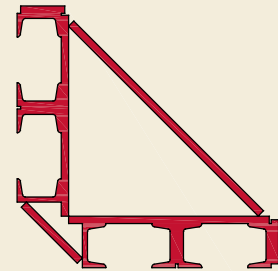

CAPACITY AND DEPTH RATINGS ACCOUNT FOR 33% OVERSTRESS FOR SHORT-TERM LOADING CONDITION.

CERTIFIED BY:
MUST BE SIGNED
& DATED

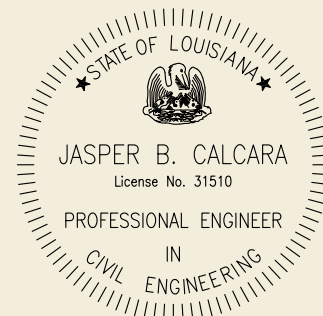



**PRO-TEC
EQUIPMENT**
4837 West Grand River Ave
Lansing, MI 48906
(800) 292-1225

ARCOSA
SHORING PRODUCTS

MANUFACTURER'S TABULATED DATA PS-TSP-324

R0

SPECIFICATIONS FOR USE

- 1) THIS TABULATED DATA SHEET IS ONLY TO BE USED TO SUPPLEMENT A SITE SPECIFIC SHORING PLAN WHEN RAILS ARE LOADED IN BENDING AND SHEAR.
- 2) PROFESSIONAL ENGINEER PREPARING SITE SPECIFIC PLAN IS RESPONSIBLE FOR CHECKING ALL COMPONENTS OF SLIDE RAIL SYSTEM AND MIDDLE RAIL ASSEMBLY FOR SOIL AND SURCHARGE LOADING ASSOCIATED WITH SITE SPECIFIC CONDITIONS.
- 3) ALL EXCAVATIONS SHALL BE IN ACCORDANCE WITH OSHA CFR 29, PART 1926, SUBPART P.
- 4) ALL EQUIPMENT COVERED UNDER THIS TABULATED DATA SHALL BE CERTIFIED PRO-TEC EQUIPMENT.
- 5) SLIDE RAIL SHORING SYSTEM SHALL BE USED IN STRICT ACCORDANCE WITH THE REQUIREMENTS OF THE MANUFACTURER.
- 6) EQUIPMENT IS NOT CERTIFIED FOR USE IF ASSEMBLIES ARE MODIFIED IN ANY WAY, UNLESS APPROVED IN WRITING BY A LICENSED ENGINEER.
- 7) CERTIFICATION IS NOT VALID IF THE SHORING SYSTEM SHOWS EXCESSIVE WEAR, IS PERMANENTLY DAMAGED, IS NOT MAINTAINED OR REPAIRED PROPERLY.

MODEL NO:

PS-TSP-324

LENGTH:

27'



ALLOWABLE MOMENT

$M = 1077 \text{ K-FT}$

ALLOWABLE SHEAR

$V = 694 \text{ KIPS}$

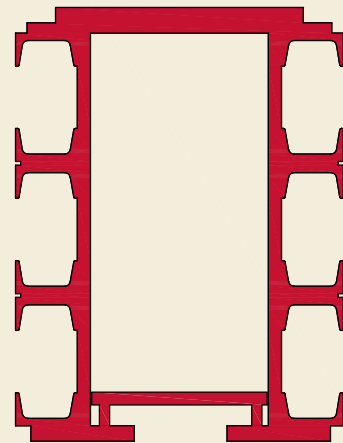

CAPACITY AND DEPTH RATINGS ACCOUNT FOR 33% OVERSTRESS FOR SHORT-TERM LOADING CONDITION.

CERTIFIED BY:

MUST BE SIGNED
& DATED

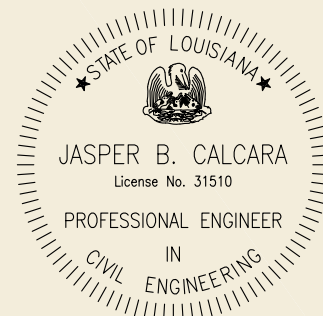



**PRO-TEC
EQUIPMENT**
4837 West Grand River Ave
Lansing, MI 48906
(800) 292-1225

ARCOSA
SHORING PRODUCTS

MANUFACTURER'S TABULATED DATA PS-TCP-312

R0

SPECIFICATIONS FOR USE

- 1) THIS TABULATED DATA SHEET IS ONLY TO BE USED TO SUPPLEMENT A SITE SPECIFIC SHORING PLAN WHEN RAILS ARE LOADED IN BENDING AND SHEAR.
- 2) PROFESSIONAL ENGINEER PREPARING SITE SPECIFIC PLAN IS RESPONSIBLE FOR CHECKING ALL COMPONENTS OF SLIDE RAIL SYSTEM AND CORNER RAIL ASSEMBLY FOR SOIL AND SURCHARGE LOADING ASSOCIATED WITH SITE SPECIFIC CONDITIONS.
- 3) ALL EXCAVATIONS SHALL BE IN ACCORDANCE WITH OSHA CFR 29, PART 1926, SUBPART P.
- 4) ALL EQUIPMENT COVERED UNDER THIS TABULATED DATA SHALL BE CERTIFIED PRO-TEC EQUIPMENT.
- 5) SLIDE RAIL SHORING SYSTEM SHALL BE USED IN STRICT ACCORDANCE WITH THE REQUIREMENTS OF THE MANUFACTURER.
- 6) EQUIPMENT IS NOT CERTIFIED FOR USE IF ASSEMBLIES ARE MODIFIED IN ANY WAY, UNLESS APPROVED IN WRITING BY A LICENSED ENGINEER.
- 7) CERTIFICATION IS NOT VALID IF THE SHORING SYSTEM SHOWS EXCESSIVE WEAR, IS PERMANENTLY DAMAGED, IS NOT MAINTAINED OR REPAIRED PROPERLY.

MODEL NO:
PS-TCP-312

LENGTH:
26'



ALLOWABLE MOMENT
 $M = 698 \text{ K-FT}$

ALLOWABLE SHEAR
 $V = 295 \text{ KIPS}$

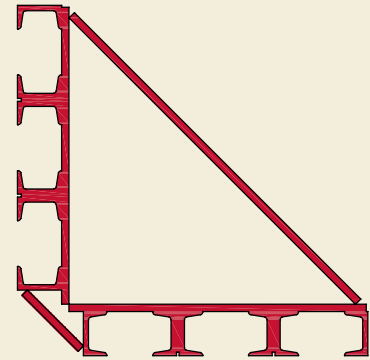

CAPACITY AND DEPTH RATINGS ACCOUNT FOR 33% OVERSTRESS FOR SHORT-TERM LOADING CONDITION.

CERTIFIED BY:
MUST BE SIGNED
& DATED

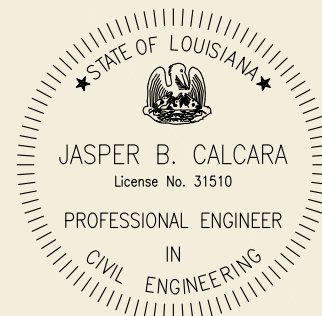



**PRO-TEC
EQUIPMENT**
4837 West Grand River Ave
Lansing, MI 48906
(800) 292-1225

ARCOSA
SHORING PRODUCTS

PRO-TEC SLIDE RAIL SHORING EXAMPLE

R0

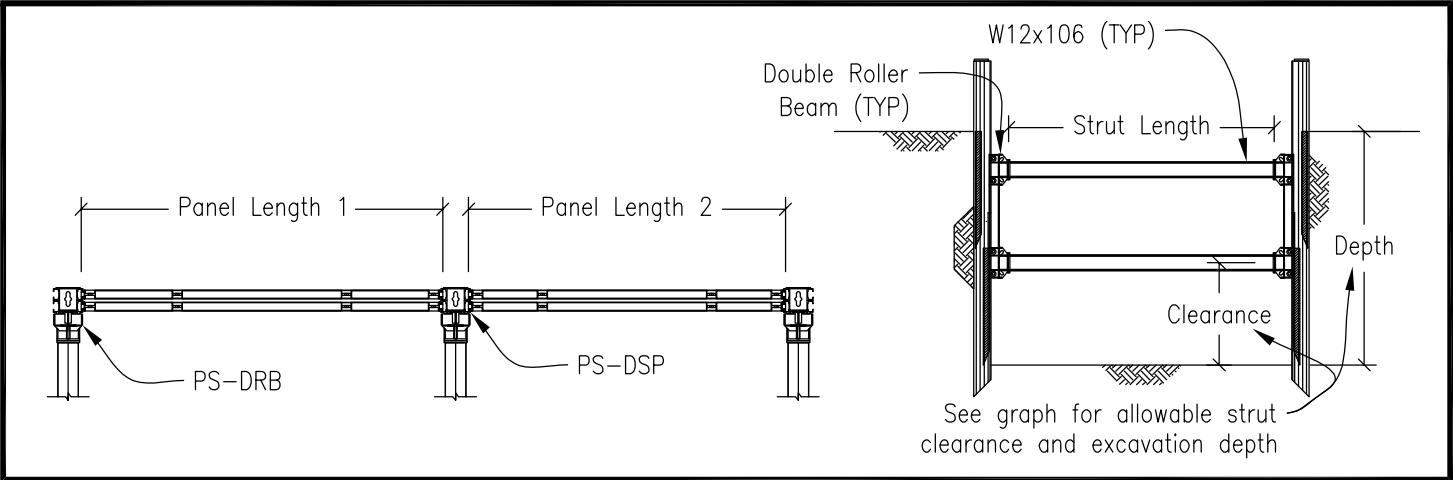

EXAMPLE:

Project Details:

- Strut = W12x106
- Post = PS-DSP
- Panel Length 1 = 20'
- Panel Length 2 = 18'
- Strut Length = 20'
- Clearance = 9'
- Soil Type = C-60

2. Find PS-DSP graph for strut length ≤ 27 ft and PTW = 20'
3. Draw horizontal line from 9' clearance to C-60 curve, then draw a vertical line down.
4. Round excavation depth down to the nearest whole number, allowable depth is 19'.

Procedure:

1. Determine Post Tributary Width (PTW)
 $PTW = \text{Panel Length 1} + \text{Panel Length 2}$
 $PTW = (20' + 18')(\frac{1}{2}) = 19'$ (round up to 20')

5. Confirm that panel length 1 & panel length 2 depth ratings are greater than or equal to 19' in C-60 soil.

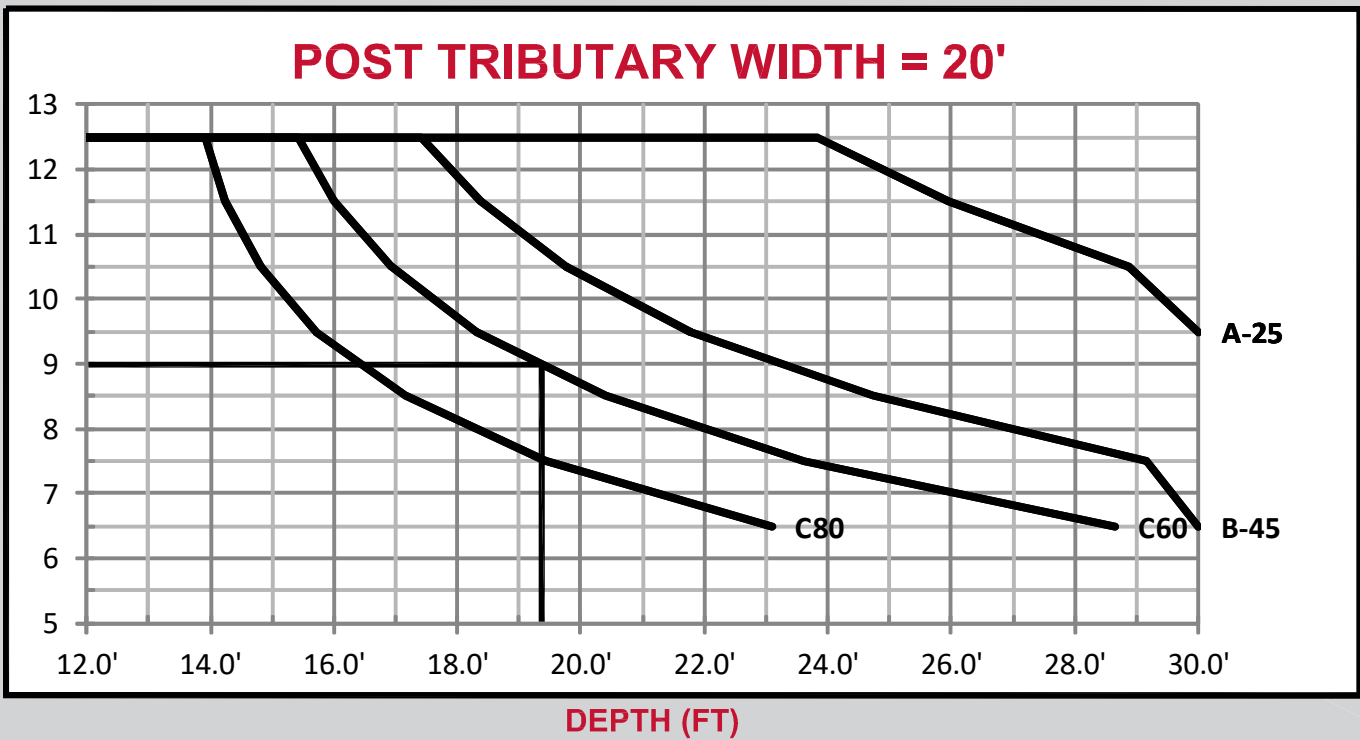



PRO-TEC
EQUIPMENT
4837 West Grand River Ave
Lansing, MI 48906
(800) 292-1225

ARCOSA
SHORING PRODUCTS

DOUBLE POST DEPTH RATINGS

R0

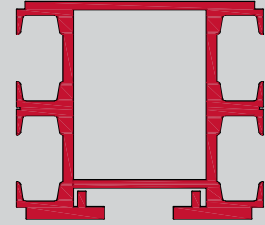
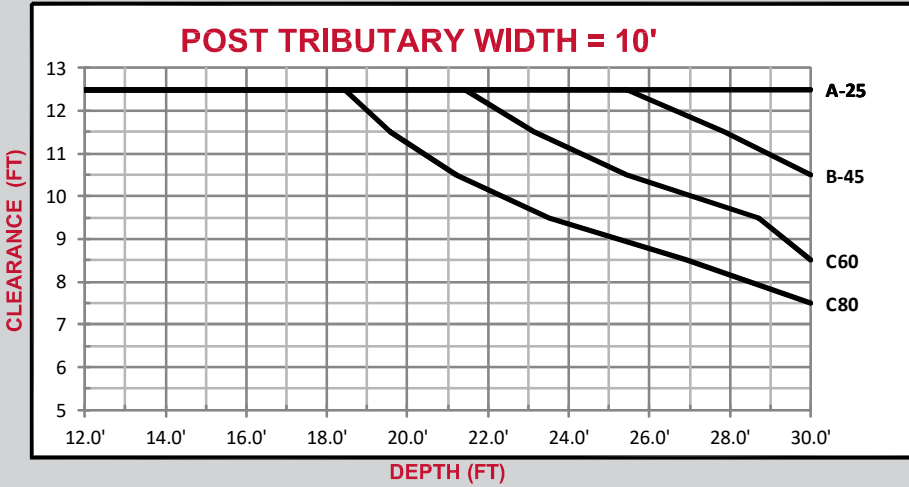

PS-DSP

ALLOWABLE

MOMENT = 564,000 ft-lbs

SHEAR = 465,000 lbs

W12x106

Max Strut Length = 27'

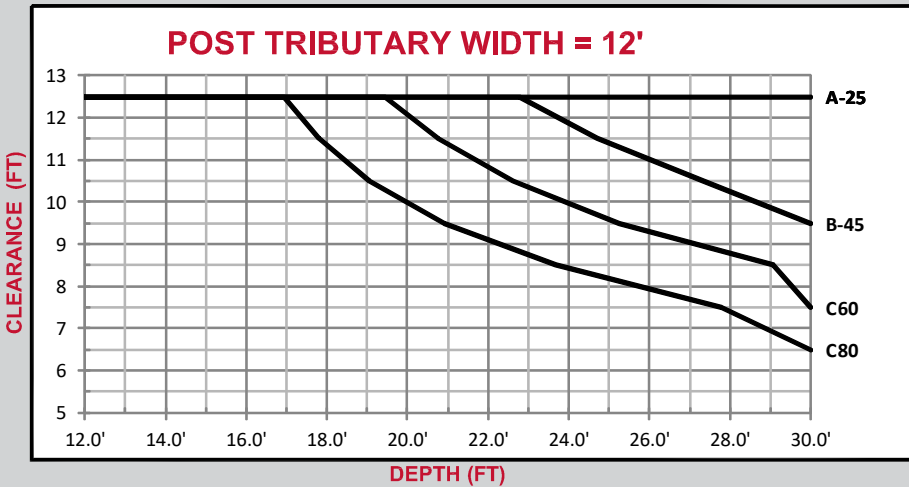

NOTES:

- 1) SEE PRO-TEC SLIDE RAIL LINEAR TABULATED DATA FOR NOTES ON INSTALLATION AND PROPER USE OF TABULATED DATA.
- 2) ALL NOTES ON PS-TB-15-0 PAGES 3 & 4 SHALL APPLY AS IF NOTED HERE.
- 3) ALL DATA ON THIS SHEET APPLIES ONLY TO THE PS-DSP POST WITH A PS-DRB AND A MAXIMUM STRUT LENGTH OF 27'.
- 4) ALL STRUTS SHALL HAVE A MINIMUM $F_y = 50\text{KSI}$.

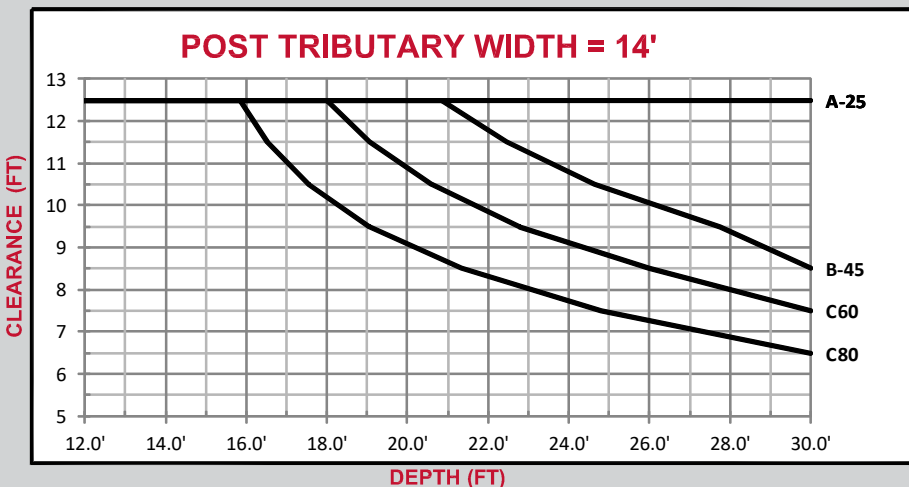

CERTIFIED BY:

MUST BE SIGNED
& DATED

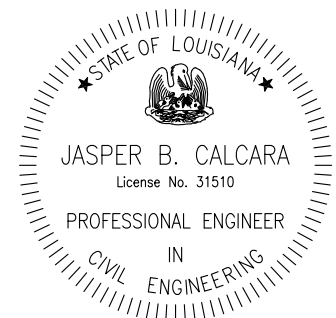



PRO-TEC
EQUIPMENT
4837 West Grand River Ave
Lansing, MI 48906
(800) 292-1225

ARCOSA
SHORING PRODUCTS

DOUBLE POST DEPTH RATINGS

R0

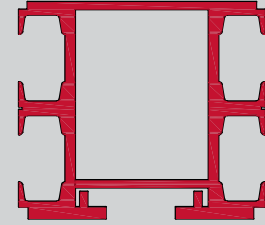
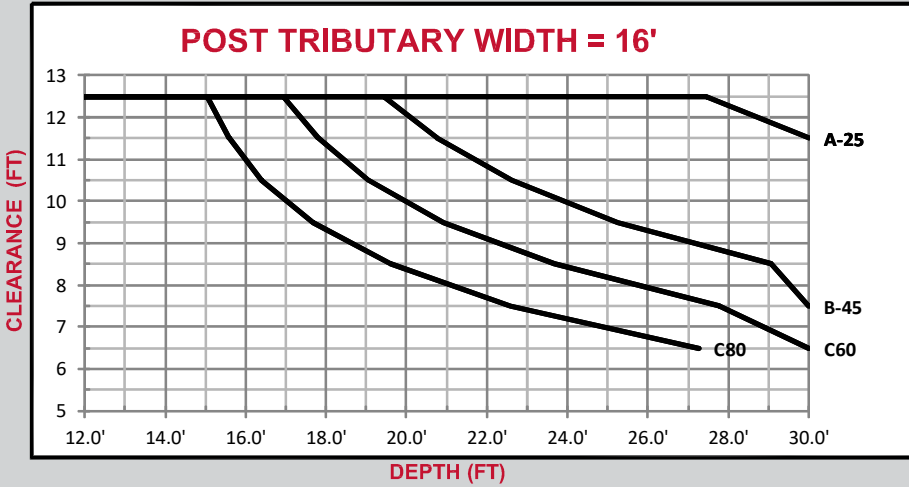

PS-DSP

ALLOWABLE

MOMENT = 564,000 ft-lbs

SHEAR = 465,000 lbs

W12x106

Max Strut Length = 27'

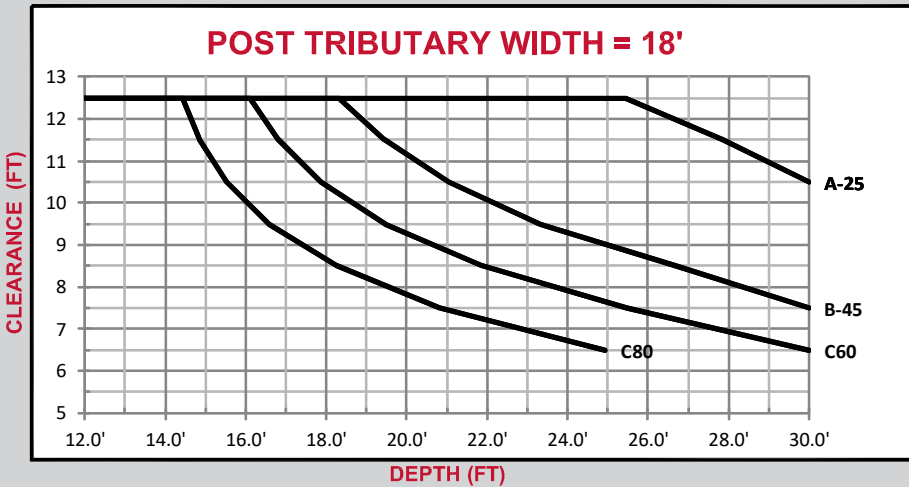

NOTES:

- 1) SEE PRO-TEC SLIDE RAIL LINEAR TABULATED DATA FOR NOTES ON INSTALLATION AND PROPER USE OF TABULATED DATA.
- 2) ALL NOTES ON PS-TB-15-0 PAGES 3 & 4 SHALL APPLY AS IF NOTED HERE.
- 3) ALL DATA ON THIS SHEET APPLIES ONLY TO THE PS-DSP POST WITH A PS-DRB AND A MAXIMUM STRUT LENGTH OF 27'.
- 4) ALL STRUTS SHALL HAVE A MINIMUM $F_y = 50\text{KSI}$.

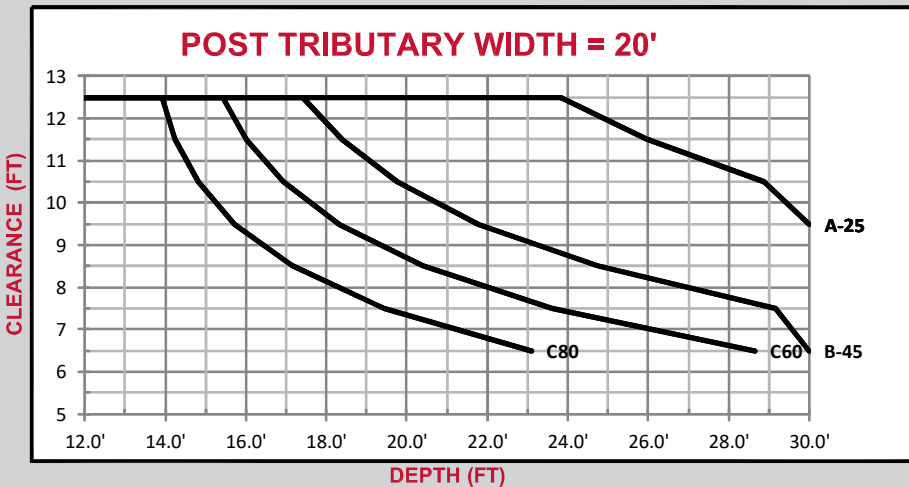

CERTIFIED BY:

MUST BE SIGNED
& DATED

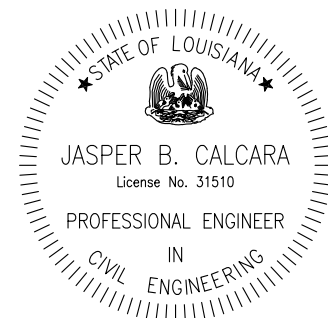



**PRO-TEC
EQUIPMENT**
4837 West Grand River Ave
Lansing, MI 48906
(800) 292-1225

ARCOSA
SHORING PRODUCTS

DOUBLE POST DEPTH RATINGS

R0

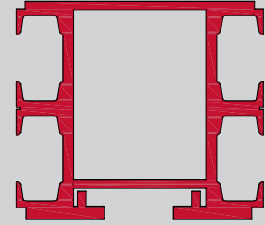
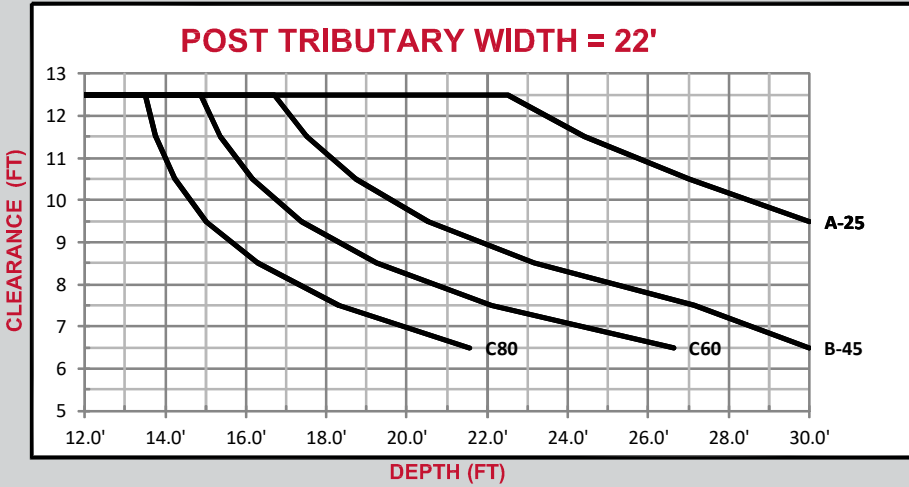

PS-DSP

ALLOWABLE

MOMENT = 564,000 ft-lbs

SHEAR = 465,000 lbs

W12x106

Max Strut Length = 27'

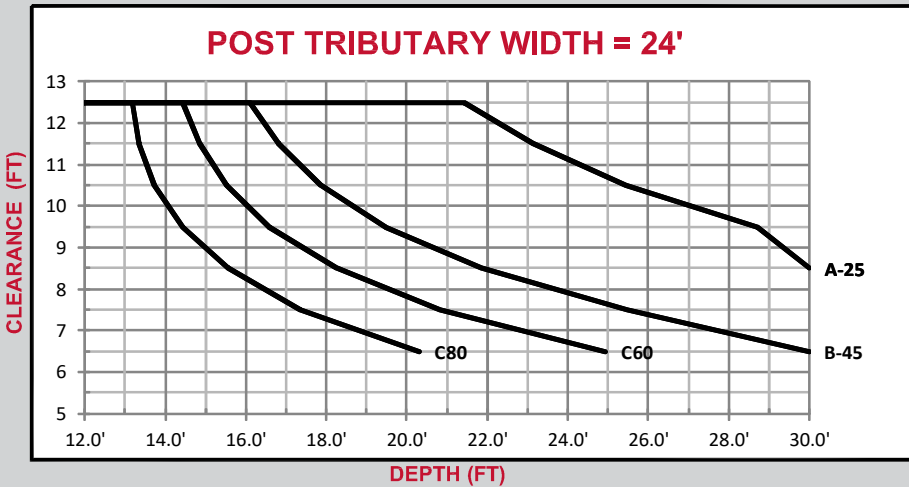

NOTES:

- 1) SEE PRO-TEC SLIDE RAIL LINEAR TABULATED DATA FOR NOTES ON INSTALLATION AND PROPER USE OF TABULATED DATA.
- 2) ALL NOTES ON PS-TB-15-0 PAGES 3 & 4 SHALL APPLY AS IF NOTED HERE.
- 3) ALL DATA ON THIS SHEET APPLIES ONLY TO THE PS-DSP POST WITH A PS-DRB AND A MAXIMUM STRUT LENGTH OF 27'.
- 4) ALL STRUTS SHALL HAVE A MINIMUM $F_y = 50\text{KSI}$.

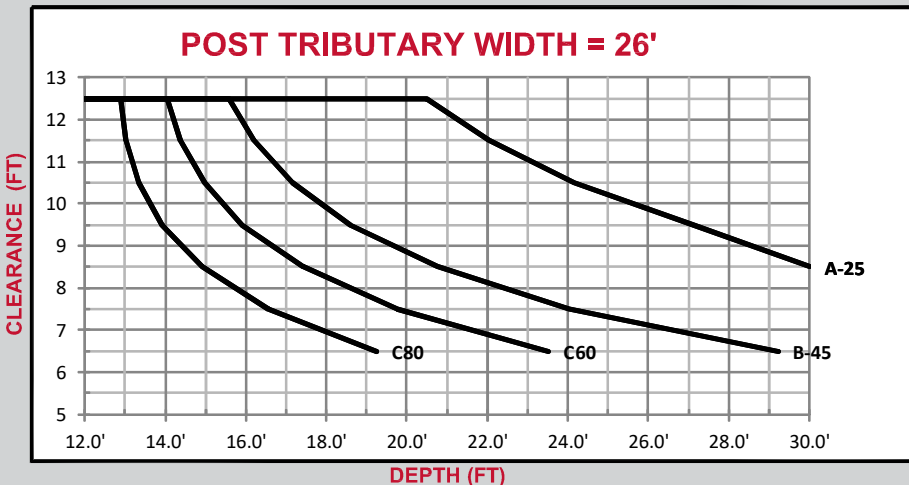

CERTIFIED BY:

MUST BE SIGNED
& DATED

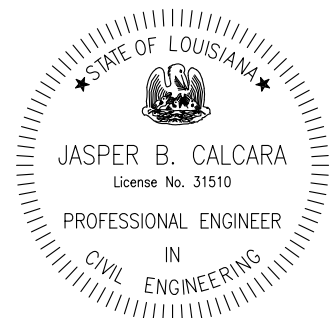



PRO-TEC
EQUIPMENT
4837 West Grand River Ave
Lansing, MI 48906
(800) 292-1225

ARCOSA
SHORING PRODUCTS

TRIPLE POST DEPTH RATINGS

R0

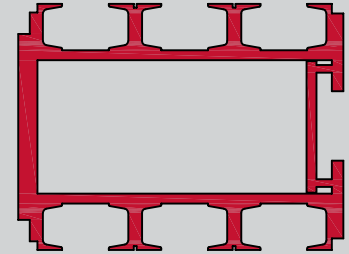
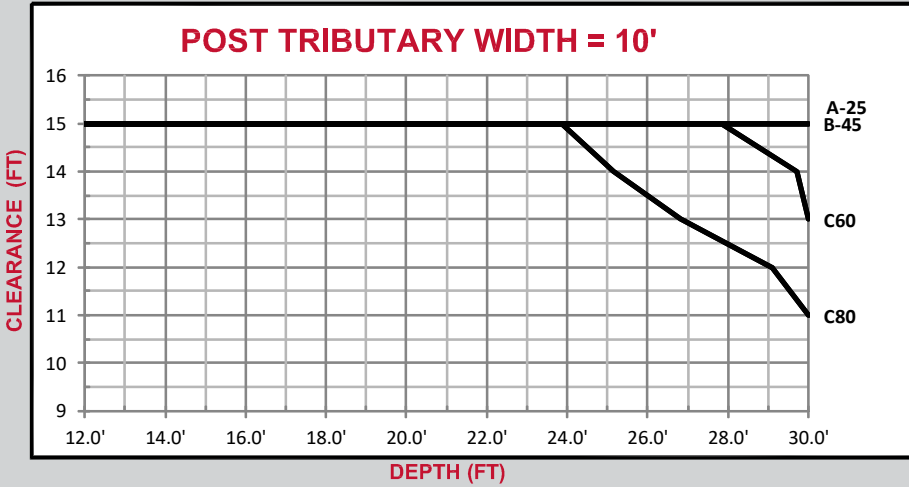

PS-TSP

ALLOWABLE

MOMENT = 1,077,000 ft-lbs

SHEAR = 694,000 lbs

W12x106

Max Strut Length = 27'

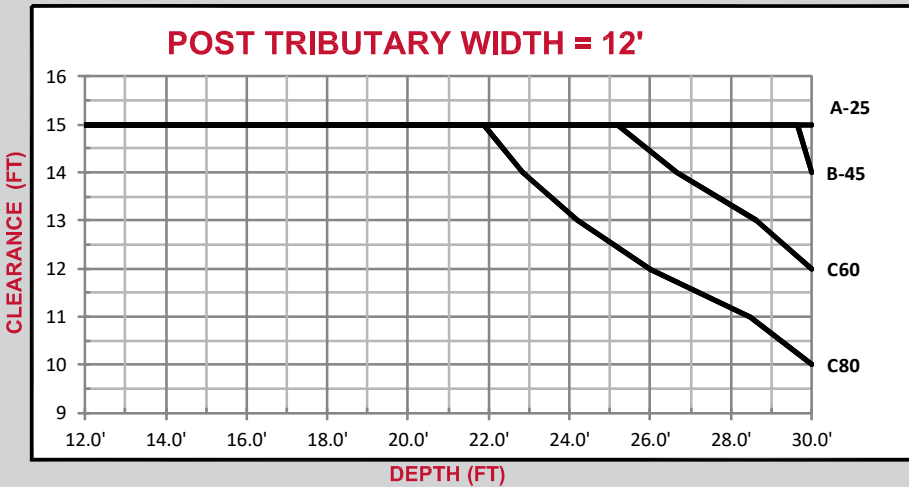

NOTES:

- 1) SEE PRO-TEC SLIDE RAIL LINEAR TABULATED DATA FOR NOTES ON INSTALLATION AND PROPER USE OF TABULATED DATA.
- 2) ALL NOTES ON PS-TB-15-0 PAGES 3 & 4 SHALL APPLY AS IF NOTED HERE.
- 3) ALL DATA ON THIS SHEET APPLIES ONLY TO THE PS-TSP POST WITH A PS-TRB AND A MAXIMUM STRUT LENGTH OF 27'.
- 4) ALL STRUTS SHALL HAVE A MINIMUM $F_y = 50\text{KSI}$.

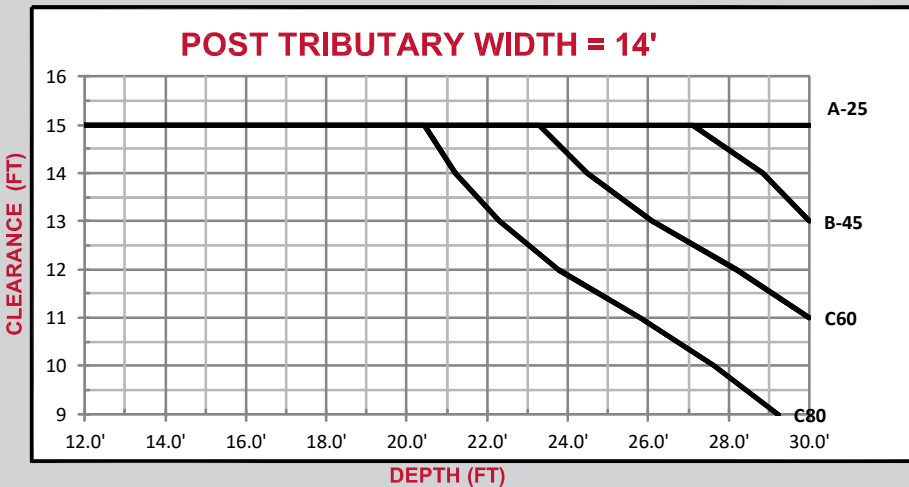

CERTIFIED BY:

MUST BE SIGNED
& DATED

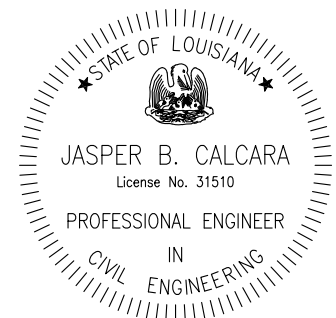



**PRO-TEC
EQUIPMENT**
4837 West Grand River Ave
Lansing, MI 48906
(800) 292-1225

ARCOSA
SHORING PRODUCTS

TRIPLE POST DEPTH RATINGS

R0

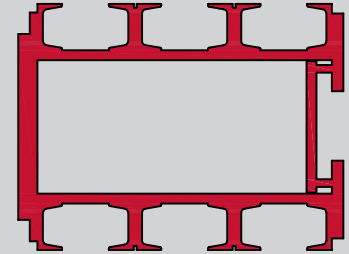
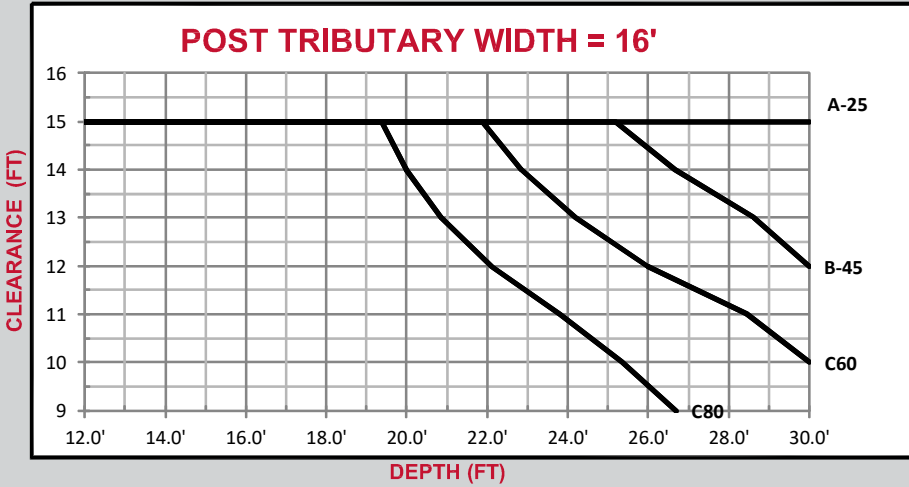

PS-TSP

ALLOWABLE

MOMENT = 1,077,000 ft-lbs

SHEAR = 694,000 lbs

W12x106

Max Strut Length = 27'

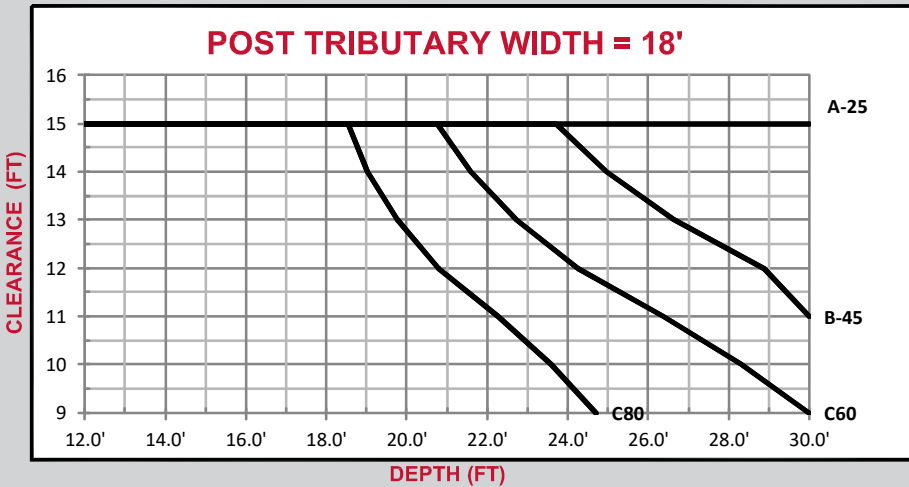

NOTES:

- 1) SEE PRO-TEC SLIDE RAIL LINEAR TABULATED DATA FOR NOTES ON INSTALLATION AND PROPER USE OF TABULATED DATA.
- 2) ALL NOTES ON PS-TB-15-0 PAGES 3 & 4 SHALL APPLY AS IF NOTED HERE.
- 3) ALL DATA ON THIS SHEET APPLIES ONLY TO THE PS-TSP POST WITH A PS-TRB AND A MAXIMUM STRUT LENGTH OF 27'.
- 4) ALL STRUTS SHALL HAVE A MINIMUM $F_y = 50\text{KSI}$.

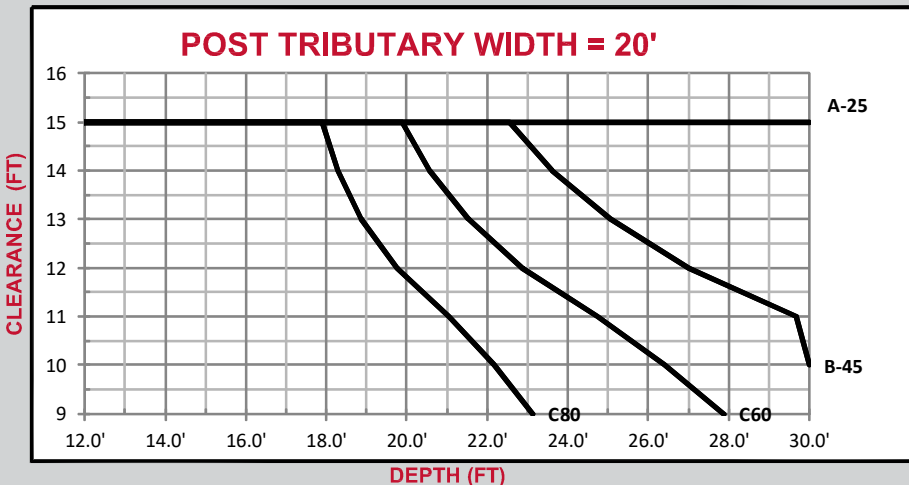

CERTIFIED BY:

MUST BE SIGNED
& DATED

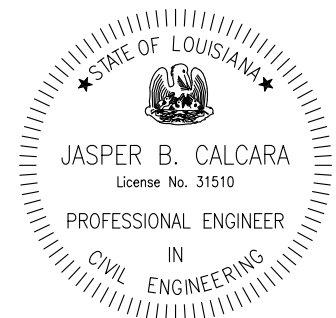



**PRO-TEC
EQUIPMENT**
4837 West Grand River Ave
Lansing, MI 48906
(800) 292-1225

ARCOSA
SHORING PRODUCTS

TRIPLE POST DEPTH RATINGS

R0

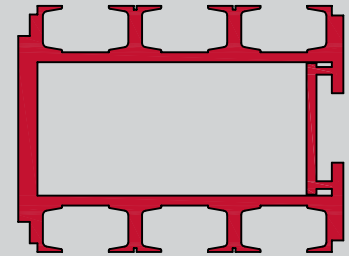
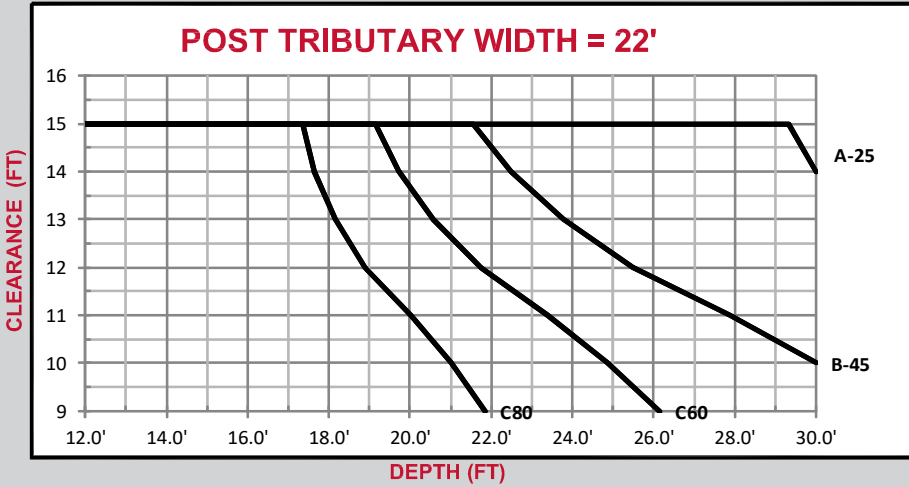

PS-TSP

ALLOWABLE

MOMENT = 1,077,000 ft-lbs

SHEAR = 694,000 lbs

W12x106

Max Strut Length = 27'

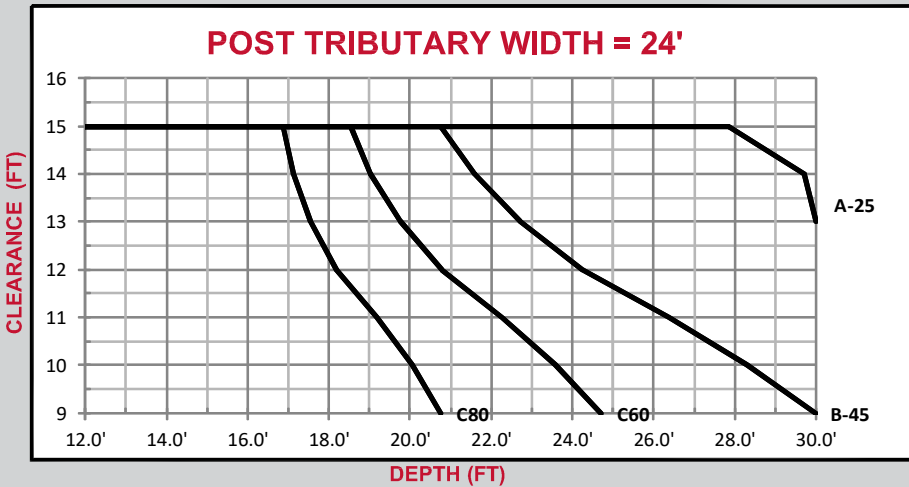

NOTES:

- 1) SEE PRO-TEC SLIDE RAIL LINEAR TABULATED DATA FOR NOTES ON INSTALLATION AND PROPER USE OF TABULATED DATA.
- 2) ALL NOTES ON PS-TB-15-0 PAGES 3 & 4 SHALL APPLY AS IF NOTED HERE.
- 3) ALL DATA ON THIS SHEET APPLIES ONLY TO THE PS-TSP POST WITH A PS-TRB AND A MAXIMUM STRUT LENGTH OF 27'.
- 4) ALL STRUTS SHALL HAVE A MINIMUM $F_y = 50\text{KSI}$.

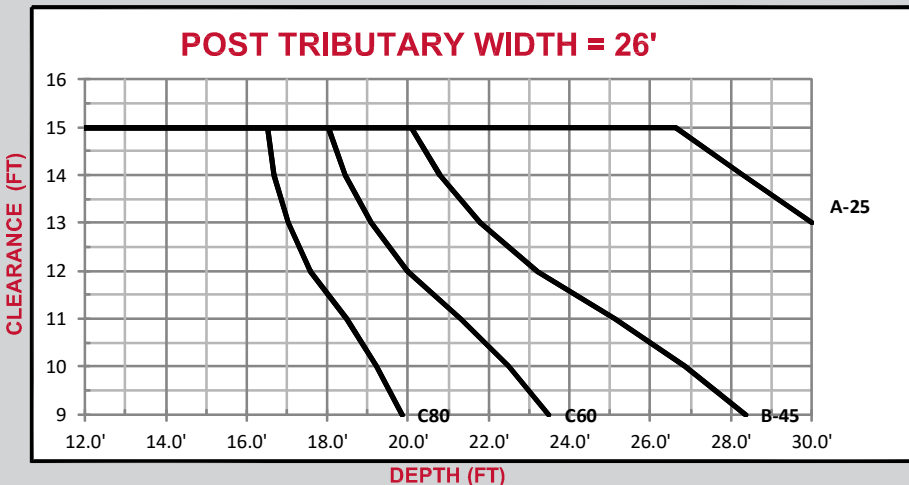

CERTIFIED BY:

MUST BE SIGNED
& DATED

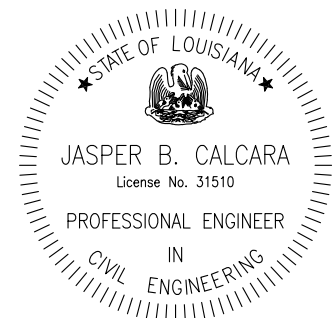



**PRO-TEC
EQUIPMENT**
4837 West Grand River Ave
Lansing, MI 48906
(800) 292-1225

ARCOSA
SHORING PRODUCTS

CORNER POST DEPTH RATINGS

R0

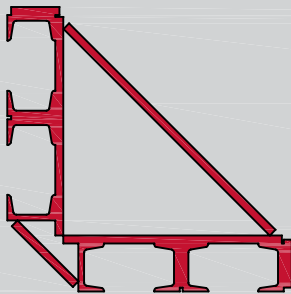
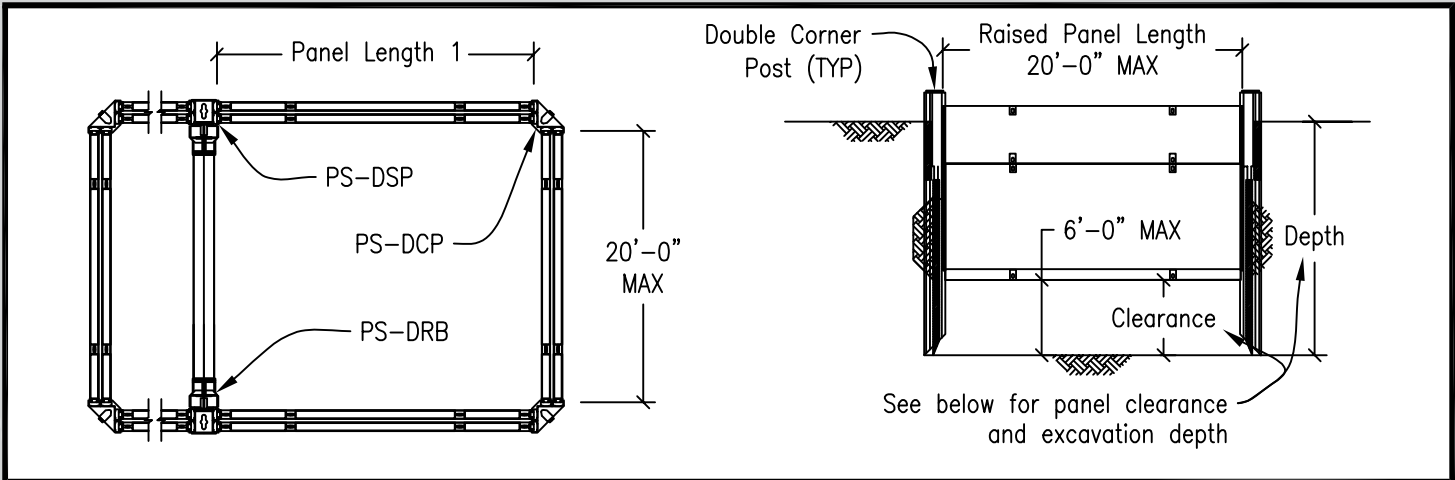

MODEL NO:
PS-DCP 216/240
LENGTH:
18'/20'

**Allowable Clearance & Depth
with the Following:**

- Max Panel Length 1 = 26'**
- Max Raised Panel Length = 20'**
- Max Clearance = 6'**
- Max Depth = 20'**
- Soil Type = A, B, C-60**

NOTES:

- 1) SEE PRO-TEC SLIDE RAIL LINEAR TABULATED DATA FOR NOTES ON INSTALLATION AND PROPER USE OF TABULATED DATA.
- 2) ALL NOTES ON PS-TB-15-0 PAGES 3 & 4 SHALL APPLY AS IF NOTED HERE.
- 3) ALL DATA ON THIS SHEET APPLIES ONLY TO THE PS-DCP POST WITH A MAXIMUM RAISED PANEL LENGTH OF 20'. SITE SPECIFIC ENGINEERING IS REQUIRED WHEN RAISED PANEL EXCEEDS 20'.
- 4) BOTH ENDS OF SHORING SHALL BE CLOSED OFF WITH CORNER POSTS AND SLIDE RAIL PANELS.
- 5) ALLOWABLE CLEARANCE IS BASED ON THE CORNER POST CAPACITY.
- 6) ADEQUACY OF RAISED END PANEL HAS NOT BEEN CHECKED FOR LOADING FROM CORNER POST.

CERTIFIED BY:
MUST BE SIGNED
& DATED

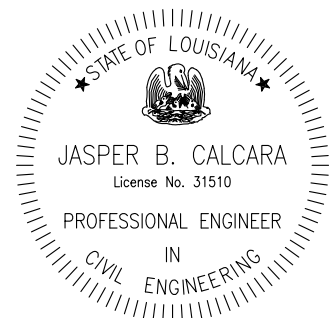



**PRO-TEC
EQUIPMENT**
4837 West Grand River Ave
Lansing, MI 48906
(800) 292-1225

ARCOSA
SHORING PRODUCTS

CORNER POST DEPTH RATINGS

R0

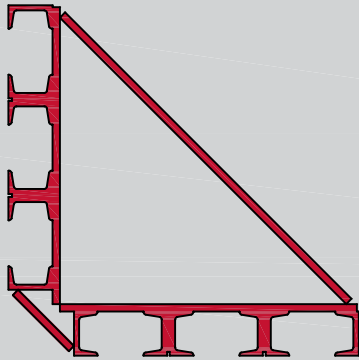
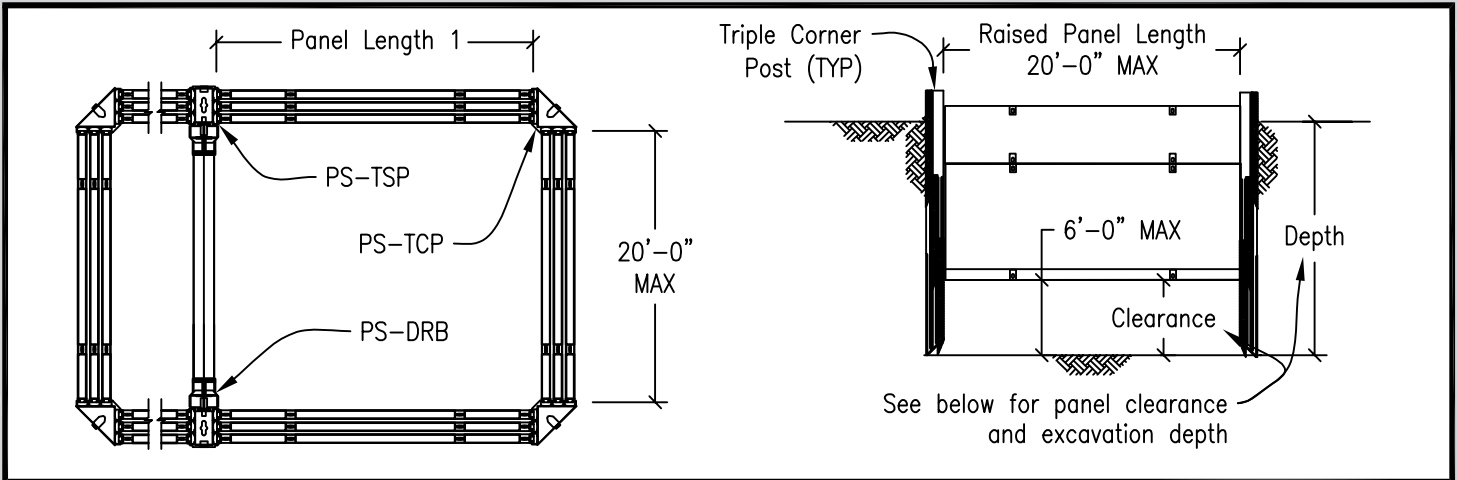

MODEL NO:
PS-TCP 312
LENGTH:
26'

**Allowable Clearance & Depth
with the Following:**

- Max Panel Length 1 = 26'**
- Max Raised Panel Length = 20'**
- Max Clearance = 8'**
- Max Depth = 24'**
- Soil Type = A, B, C-60**

NOTES:

- 1) SEE PRO-TEC SLIDE RAIL LINEAR TABULATED DATA FOR NOTES ON INSTALLATION AND PROPER USE OF TABULATED DATA.
- 2) ALL NOTES ON PS-TB-15-0 PAGES 3 & 4 SHALL APPLY AS IF NOTED HERE.
- 3) ALL DATA ON THIS SHEET APPLIES ONLY TO THE PS-TCP POST WITH A MAXIMUM RAISED PANEL LENGTH OF 20'. SITE SPECIFIC ENGINEERING IS REQUIRED WHEN RAISED PANEL EXCEEDS 20'.
- 4) BOTH ENDS OF SHORING SHALL BE CLOSED OFF WITH CORNER POSTS AND SLIDE RAIL PANELS.
- 5) ALLOWABLE CLEARANCE IS BASED ON THE CORNER POST CAPACITY.
- 6) ADEQUACY OF RAISED END PANEL HAS NOT BEEN CHECKED FOR LOADING FROM CORNER POST.

CERTIFIED BY:
MUST BE SIGNED
& DATED

